

'QB' Bulldog Quick Release Kit Fitting Instructions



The Kit Includes:

- Item 1 - Cam Release
- Item 2 - Retaining Bolt with 'Safety Head'
- Item 3 - Retaining Washer - Hard Faced
- Item 4 - Disc Spring
- Item 5 - Special Locking Nut
- Item 6 - Thin 12mm Lock Nut
- Item 7 - Tubular Detachable Handle

Existing Fastener Items To Be Used:

- Item 8 - Existing Retaining Washer
- Item 9 - Existing Disc Spring

Step No 1.

Remove the 12mm adjusting bolt, plain washer and nyloc nut and discard. Take off the existing retaining washer (item 8) and disc spring (item 9) and place aside (these 2 items are to be used on the bottom of the stabiliser Fig 2).

Step No 2.

From the kit assemble items 1 to 4 as Fig 1 shows.

Step No 3.

Slide the retaining bolt (item 2) through the stabiliser and fit the existing stabiliser disc spring (item 9) and retaining washer (item 8) up to the bottom of the stabiliser as Fig 2 shows.

Step No 4.

Fit the handle (item 7) onto cam release spigot to act as a lever and hold horizontal. Fit the special locking nut (item 5) - (take care that the dome is at the bottom), and run it up the thread until the two disc springs bite into the stabiliser.

Step No 5.

Try the push/pull force at the end of the spring arm (as per the standard fitting instructions). The force can be measured with a set of bathroom scales and should be approx **60lbs - this is not a torque figure. Please do not use a torque wrench.** Tighten or loosen the special locking nut (item 5) until the correct setting is obtained. Use the handle on the spigot to prevent movement of retaining bolt.

Step No 6.

Fit the thin 12mm lock nut (item 6) and tighten up to the domed face of the special locking nut. Use two spanners and take care not to move the special locking nut (item 5).

Step No 7.

Using the handle supplied lift up the cam to release the pressure off the friction discs. It should be now relatively easy to move the spring arm from side to side. If you consider it not easy enough, check the force at the end of the spring arm and re-adjust the lock nuts as necessary.

Step No 8.

It is advised that a light smear of grease at the end of the thread will help prevent weathering. After 50 miles, check the tightness of the thin lock nut to the special locking nut (items 6 and 5).

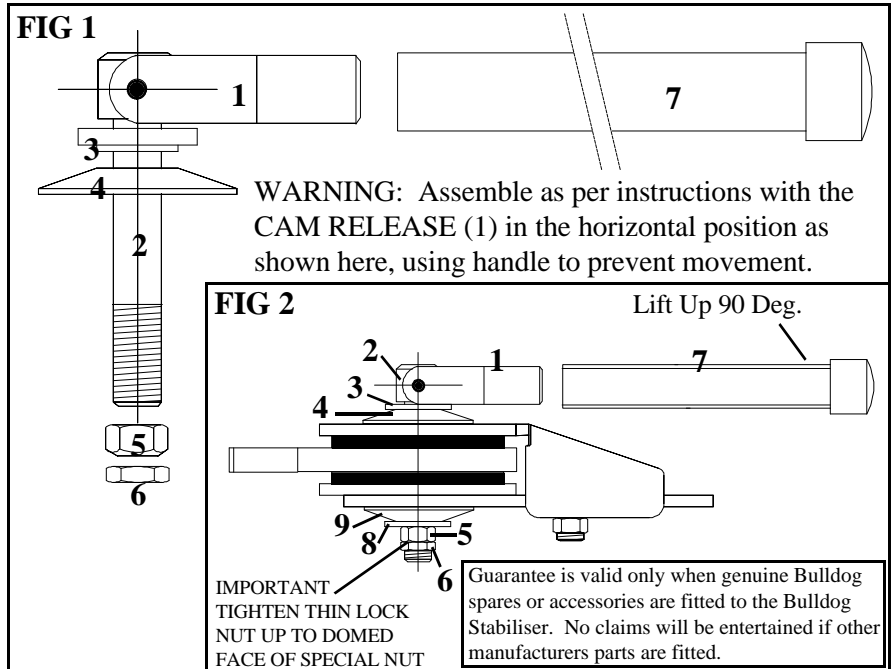

BULLDOG SECURITY PRODUCTS LIMITED

Units 2,3,4 Stretton Road, Much Wenlock, Shropshire, TF13 6DH. Tel: 01952 728171 Fax: 01952 728117
email: sales@bulldog-security-products.co.uk web site: <http://www.bulldog-security-products.co.uk>